

The book was found

Zen Of Analog Circuit Design

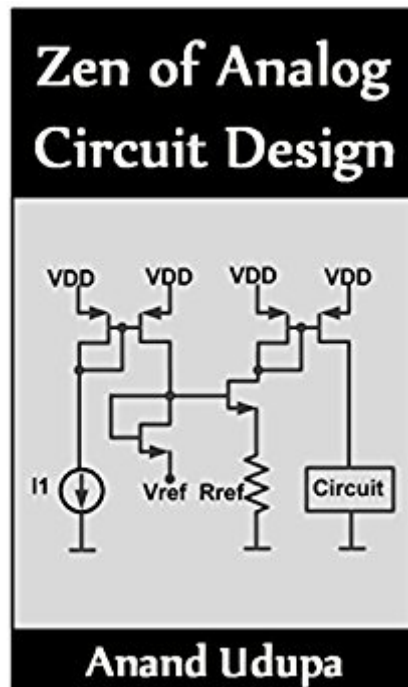

Synopsis

Zen of Analog Circuit Design RECENTLY UPDATED WITH NEW CONTENT For two years from 2011 till 2013, I taught a course titled Analog Design for all which covered concepts starting with MOS transistor behavior and progressed till the design of two stage amplifiers. The course introduced concepts in a manner that led the student to the synthesis of new circuits, not merely their analysis. But I still felt that there was a more intuitive way to introduce Analog Circuit Design, one that would bring out the beauty of the subject so that the student could "stop and smell the roses". But why a "Zen of Analog"? Because the foundational concepts in Analog closely mirror human relationships! The purpose of this book is to take a simplified and intuitive path to unlock some profound secrets of Analog. The protagonist of this book is Ang-Lao, a medieval monk who brings his insights into the Analog world to solve the challenges in human relationships. The book addresses a problem statement that much of Analog Circuit Design tries to solve - how do you realize an ideal buffer? It starts with the simple concepts of voltage sources and current sources. From the I-V curve of the MOS transistor, we see how it behaves much like a Voltage controlled current source (VCCS). The inherent challenge in getting even a simple two-transistor circuit to work is the conflict arising from having two such current source-like elements in series. The digital inverter is shown to be one such circuit that can function like an analog amplifier, albeit over a narrow range of input voltage. The effect of loading on such a circuit is illustrated graphically and is shown as an added challenge in getting it to work in an analog manner. Having understood the complications involved, we see how through the strikingly simple but immensely powerful concept of feedback, one of the two transistors can be modified subtly to make it behave like a voltage source. In that process, we realize our first approximation to an ideal analog buffer. We then see how manifestations of the same concept leads us to the synthesis of a whole bunch of two transistor circuits - source followers, common source amplifiers with gm-load and with diode-connected load. The concepts used in synthesis of such elegant circuits are also extended to the analysis of much more complex circuits, for example, a Voltage to Current (V2I) conversion circuit. We end the journey by introducing the small signal parameters, g_m , g_{ds} , showing the calculations for the gain and output impedance of our circuits, and quantifying how good a buffer the Source follower really is. This sets the stage on what we need to do to improve on it. On the quest to realize our ideal buffer, the narrative switches between concepts of Electronics and the story of Aman-Ra, an engineer from Medieval Egypt. Struggling with his relationships, his guiding light comes in the form of Ang-Lao, who teaches him the secret to happy relationships. For some, this book will signal the end of the fear of Analog. For others, it will be the start of a love story. Concepts covered are I-V

characteristics of Voltage & Current sources
Ideal & non-ideal sources
Controlled sources
Active and passive elements
I-V characteristics of a MOSFET in saturation
MOS transistor as a Voltage controlled current source
Digital inverter as Analog amplifier
Operating/ Bias point
Common source (CS) amplifier
Effect of loading on a CS amplifier
Feedback
How can you make a MOSFET behave like a voltage source?
Synthesis of a CS amplifier with diode-connected load
Analysis of a V2I circuit including an introduction to current mirror
Synthesis of CS amplifier with gm-load
Synthesis of source follower circuit
Small-signal parameters: gm, gds
Small-signal gain and output impedance

Book Information

File Size: 4240 KB

Print Length: 105 pages

Publication Date: June 1, 2015

Sold by: Digital Services LLC

Language: English

ASIN: B00YQ6XTW0

Text-to-Speech: Enabled

X-Ray: Not Enabled

Word Wise: Not Enabled

Lending: Not Enabled

Enhanced Typesetting: Enabled

Best Sellers Rank: #169,254 Paid in Kindle Store (See Top 100 Paid in Kindle Store) #8 in Kindle Store > Kindle eBooks > Engineering & Transportation > Engineering > Electrical & Electronics > Electronics > Transistors #9 in Kindle Store > Kindle eBooks > Engineering & Transportation > Engineering > Electrical & Electronics > Transistors #14 in Books > Engineering & Transportation > Engineering > Electrical & Electronics > Electronics > Transistors

Customer Reviews

Most books on Analog Design take an equation based approach leading to clouding the reader's mind with much that is of little significance. The equations typically contain so many terms that the essential idea behind the equation remains elusive to the lost reader. Let me take a moment to include a quote by Richard Hamming here - 'The purpose of computation is not numbers; it is insight'. This book is a goldmine of insight. Starting with very simple ideas, the book introduces the reader to progressively more complicated circuits, while building on the ideas presented up to that

point. It is a testimony to the writer's craft and expertise to have written an entire book where all the essential ideas involve just 2 transistors; and yet there is much left to the reader to reflect upon. The writing helps shape the way the reader ought to think about circuits. There is little doubt that the thought process explained in the book, is at some level, what goes on in the mind of a circuit design expert as they set to analyze/design a circuit. It would not be an exaggeration to say that this is the first Analog design book of its kind. This is the way Analog Design needs to be taught. It gives the reader a peek into the mind of a circuit design wizard. The human-relations angle lends a touch of occasional lightness and does not detract from circuit design which is really the core. I keenly look forward to the rest of the series ! I strongly recommend this book to all those who wish to develop a strong foundation and intuition for analog design.

Pretty amazing book. Very interesting way of looking at Analog Circuit design through simple stories and real psychological analogies. Thoroughly enjoyed it!

Not enough content to make it worth \$5.

[Download to continue reading...](#)

Zen and Zen Classics volume 1: From the Upanishads to Huineng (Zen & Zen Classics) Zen: Zen For Beginners - The Ultimate Guide To Incorporating Zen Into Your Life - A Zen Buddhism Approach To Happiness And Inner Peace Designing Dynamic Circuit Response (Analog Circuit Design) Zen of Analog Circuit Design Winter Circuit (Show Circuit Series -- Book 2) (The Show Circuit) Zen:How to Live a Zen Lifestyle in a Modern Society (Zen, Buddhism, Mindfulness, Yoga) Zen: Zen for Beginners: The Complete Guide to Achieving Presence and Inner Peace (Meditation, Buddhism, Zen Buddhism for Beginners, Happiness) Analog Circuit Design: Art, Science and Personalities (EDN Series for Design Engineers) CMOS Analog Circuit Design (The Oxford Series in Electrical and Computer Engineering) Analog Integrated Circuit Design Analog Filter and Circuit Design Handbook CMOS Analog Circuit Design High-Frequency Analog Integrated Circuit Design (Wiley Series in Microwave and Optical Engineering) VLSI Analog Signal Processing Circuits: Algorithm, Architecture, Modeling, and Circuit Implementation Analog Methods for Computer-Aided Circuit Analysis and Diagnosis (Electrical and Computer Engineering) Summer Circuit (Show Circuit Series -- Book 1) Circuit Engineering: The Beginner's Guide to Electronic Circuits, Semi-Conductors, Circuit Boards, and Basic Electronics 2015 Federal Circuit Yearbook: Patent Law Developments in the Federal Circuit Color Zen Adult Coloring Book 2: Easy Breezy Garden Patterns (Color Zen Adult Coloring Books) (Volume 2) In a Zen Garden: Words of Wisdom for the Zen

Gardener

[Dmca](#)